

# V-Drive<sup>+</sup>/N-Drive economy

Operating Manual

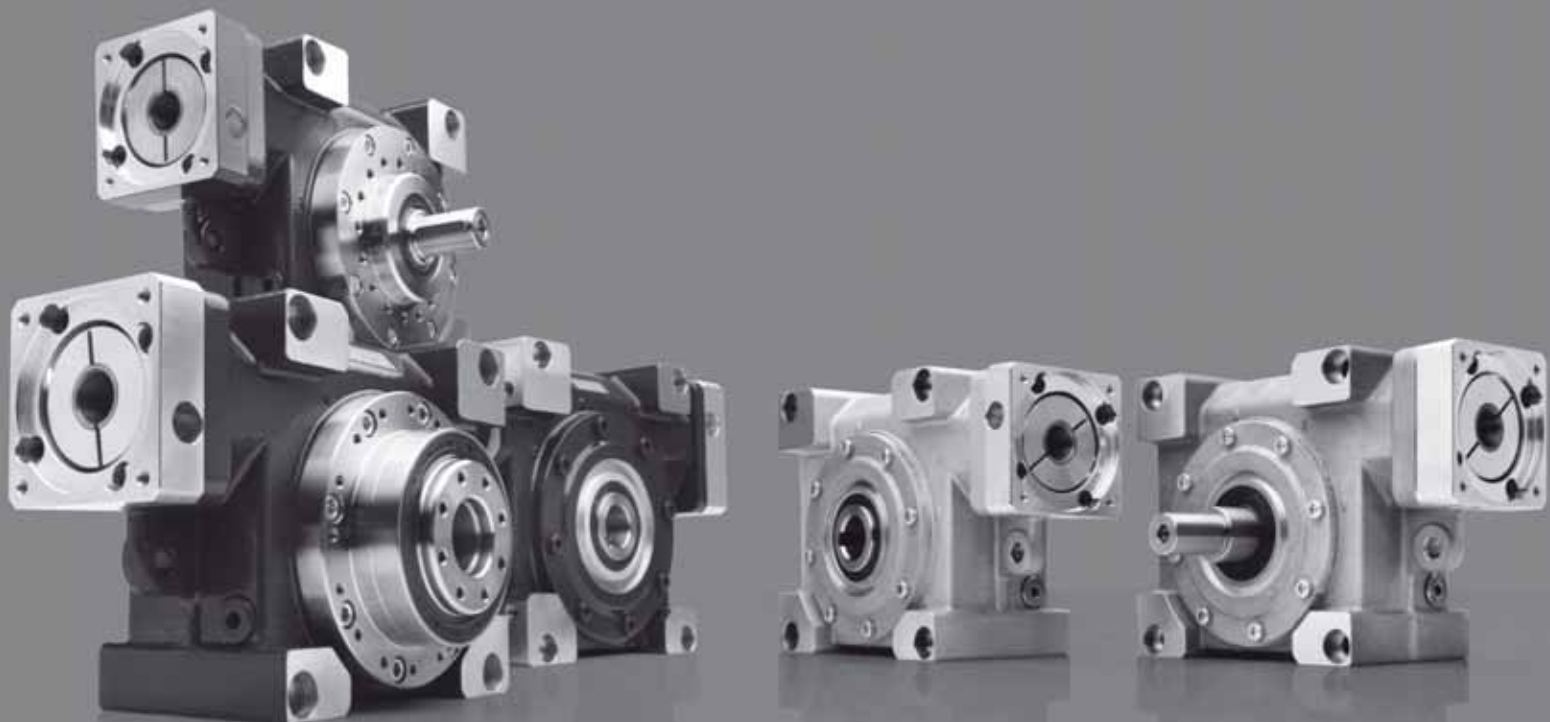

## Revision history

Revision	Date	Comment	Chapter
01	11.07.2002	New version	All
02	29.10.2002	Technical data updated	All
02a	01.07.2008	Layout WITTENSTEIN	All
03	11.05.2009	Technical data updated	4.3.2, 7.1
04	01.12.2009	Machinery Directive; V-Drive <sup>+</sup> /V-Drive economy	All
05	05.05.2010	Technical data updated	4.3, 6.3.4
06	02.08.2010	Technical data updated, change of telephone number Service department	1.1, 6.2.3
07	16.09.2011	Gearhead size 040	All
07a	08.02.2013	2. action instruction	8.3.1
08	16.05.2013	Shrink disk	3.3.1, 6.3, 9.2.2

### Service

In case you have technical questions,  
please contact:

#### **WITTENSTEIN alpha GmbH**

Customer Service  
Walter-Wittenstein-Straße 1  
D-97999 Igersheim

Tel.: +49 7931 493-12900

Fax: +49 7931 493-10903

E-mail: [service-alpha@wittenstein.de](mailto:service-alpha@wittenstein.de)

#### © WITTENSTEIN alpha GmbH 2013

This documentation is copyright protected.

**WITTENSTEIN alpha GmbH** reserves all the rights to photo-mechanical reproduction, copying, and the distribution by special processes (such as computers, file media, data networks), even in parts.

Subject to technical and content changes without notice.

**1 Contents**

<b>1 Contents</b>	<b>1</b>		
1.1 Service Contact	2		
<b>2 General Information</b>	<b>2</b>		
2.1 Description, Designations	2		
2.2 Whom does this manual concern?	2		
2.3 Which signs and symbols are referred to in this manual?	2		
2.4 Exclusion of liability	2		
2.5 Modifications, Reconstructions	2		
2.6 EC Machinery Directive	2		
2.7 Technical Modifications	2		
2.8 Copyright	2		
<b>3 Safety</b>	<b>3</b>		
3.1 Intended Use	3		
3.2 Improper Use	3		
3.3 Safety Instructions	3		
3.3.1 General Safety Instructions	3		
3.4 Tightening Torques	4		
3.5 In case of fire	4		
3.5.1 Suitable extinguishing agents, Protective equipment	4		
3.5.2 Unsuitable extinguishing agents	4		
3.5.3 Additional Information	5		
<b>4 Technical Specifications</b>	<b>5</b>		
4.1 Design	5		
4.1.1 "VDT+" with output flange	5		
4.1.2 "VDS+" with output shaft	5		
4.1.3 "VDS+" with output shaft on both sides	6		
4.1.4 "VDSe" with output shaft	6		
4.1.5 "VDSe" with output shaft on both sides	6		
4.1.6 "VDH+/VDHe" with hollow output shaft	6		
4.2 Weight	6		
4.3 Quantity of lubricant and types	6		
4.3.1 Lubricant quantities VDT+, VDS+ und VDSe	7		
4.3.2 Lubricant quantities VDH+, VDS+ with output shaft on both sides and VDHe	7		
4.4 Performance Statistics	8		
4.5 Noise emission	8		
4.6 Identification Plate	8		
4.7 Ordering Key	9		
<b>5 Delivery Status, Transport, Storage</b>	<b>9</b>		
5.1 Delivery Status	9		
5.2 Transport	10		
5.2.1 Transport using hoisting equipment	10		
5.3 Storage	10		
<b>6 Mounting, Putting into Operation</b>	<b>11</b>		
6.1 Preparation	11		
6.2 Mounting the Motor	11		
6.2.1 General Information	11		
6.2.2 Tools for tightening the clamping hub	11		
6.2.3 Assembly	12		
6.3 Mountings on the gear output side	13		
6.3.1 Mountings on the output flange (version VDT+)	13		
6.3.2 Mountings on the output shaft (version VDS+/VDSe, VDS+/VDSe with output shaft on both sides)	13		
6.3.3 Assembly on the hollow shaft with shaft key (version VDH+/VDHe with groove)	14		
6.3.4 Mounting on the hollow output shaft with shrink disk (version VDH+/VDHe smooth)	14		
6.3.5 Mounting the gearhead onto your machine	16		
6.4 Putting into operation	16		
6.5 Changing the torsional flank backlash (optional)	17		
<b>7 Operation</b>	<b>17</b>		
7.1 Operating conditions	17		
<b>8 Maintenance</b>	<b>17</b>		
8.1 Shutdown, preparation	17		
8.2 Inspection schedule	18		
8.3 Maintenance Work	18		
8.3.1 Visual Inspection	18		
8.3.2 Checking the tightening torques	18		
8.3.3 Oil change	18		
8.4 Start-up after maintenance work	20		
8.5 Malfunction list (troubleshooting)	20		
<b>9 Dismantling</b>	<b>20</b>		
9.1 Preparation	20		
9.2 Disassembling the gearhead	20		
9.2.1 Dismantling of a slip-on gear mechanism with feather key	21		
9.2.2 Dismantling of a slip-on gear mechanism with shrinkable disk	21		
9.3 Disassembling the motor	22		
<b>10 Disposal</b>	<b>22</b>		
10.1 Lubricants	22		
10.2 Sealing rings	22		
10.3 Metal	22		
<b>11 Appendix</b>	<b>23</b>		
11.1 Tightening torques for common thread sizes in general mechanics	23		
11.2 Setting the torsional flank backlash	23		

## 1.1 Service Contact

Please contact our Customer Service Department if you have any technical questions:

### **WITTENSTEIN alpha GmbH**

Customer Service  
Walter-Wittenstein-Str. 1  
D-97999 Igersheim

Tel.: +49 7931 493-12900  
Fax: +49 7931 493-10903  
E-Mail: service-alpha@wittenstein.de

## 2 General Information

If this manual is supplied with an amendment (e.g. for special applications), then the information in the amendment is valid. Contradictory specifications in this manual thereby become obsolete.

The original instructions were prepared in German; all other language versions are translations of these instructions.

### 2.1 Description, Designations

The low-backlash angle gear V-Drive+/V-Drive economy, hereafter referred to as gearhead, is installed in the "T" (output flange), "S" (output shaft) and "H" (hollow output shaft) versions.

### 2.2 Whom does this manual concern?

This manual concerns all persons who install, operate, or maintain this gear reducer. They may only carry out work on the gear reducer, if they have read and understood this operating manual. Please pass the safety instructions on to other persons as well.

### 2.3 Which signs and symbols are referred to in this manual?

- Ü An "action instruction", which requires you to carry out an action.
  - Ñ With a "check" you can specify whether the device is ready for the next work stage.
  - J A "usage tip" shows you an option of facilitating or improving operations.
- The safety instructions symbols are described in section 3 "Safety".

### 2.4 Exclusion of liability

The manufacturer does not accept liability for damage or injury ensuing from improper handling of the gear reducer.

### 2.5 Modifications, Reconstructions

Modifications or reconstructions of the gear reducer may only be carried out with the express written authorisation of **WITTENSTEIN alpha**.

### 2.6 EC Machinery Directive

The gearhead is considered a "machine component" and is therefore not subject to the EC Machinery Directive 2006/42/EC.  
Operation is prohibited within the area of validity of the EC directive, until it has been determined that the machine, in which this product is installed, corresponds to the regulations within this directive.

### 2.7 Technical Modifications

**WITTENSTEIN alpha** reserves the right of carrying out technical modifications to improve the product.

### 2.8 Copyright

© 2013, **WITTENSTEIN alpha GmbH**

### 3 Safety

#### 3.1 Intended Use

The gearhead is designed for use in machines and terotechnology. Please refer to our catalogue or our Internet page for the maximum permitted torques and speeds: [www.wittenstein-alpha.de/en](http://www.wittenstein-alpha.de/en).

Ü Please consult our Customer Service Department (see 1.1) if your gearhead is older than a year. In this way you receive valid data.

#### 3.2 Improper Use

Every usage which exceeds the limits stated above (especially higher torques and speeds) is not compliant with the regulations, and is thus prohibited.

The operation of the gear reducer is prohibited if:

- it was not mounted according to regulations (e.g., securing the motor),
- it was not installed according to regulations (e.g., securing screws),
- the gear reducer is very soiled,
- it is operated without lubricant.

#### 3.3 Safety Instructions

The following symbols are used in this operating manual to warn you of hazards:



##### **DANGER!**

This symbol warns you of danger of injury to yourself and others.



##### **Attention**

This symbol warns you of the risk of damage to the gear reducer.



##### **Environment**

This symbol warns of environmental pollution risk.

In addition to the safety specifications mentioned in this operating manual, the general and also the local regulations on the prevention of accidents (for instance, personal safety equipment) and on environmental protection should be observed.

##### 3.3.1 General Safety Instructions

###### Working on the gearhead



##### **DANGER!**

Inappropriately executed work can lead to injury and damage.

Ü Make sure that the gearhead is only installed, maintained, and dismantled by trained technicians.



##### **DANGER!**

Foreign bodies spinning through the air can cause grave injury.

Ü Before putting the gearhead into operation, check that there are no foreign bodies or tools near the gearhead.

###### Operation



##### **DANGER!**

Touching hot surfaces can lead to burns.

Ü Do not touch the gearheads if their operating temperatures are too high, or use suitable safety equipment (e.g. gloves).



##### **DANGER!**

A damaged gearhead can cause accidents and injury.

Ü Never use a gearhead that has been overloaded to due misuse or a machine accident (see chapter 3.2 „Improper Use“).

Ü Replace the affected gearhead, even if no external damage is visible.



**DANGER!**

Rotating machinery can lead to injury. There is danger of being trapped or pulled in!  
 Ü Keep a sufficient distance to rotating machinery.

**Maintenance**



**DANGER!**

An unintentional start of the machine during maintenance work can lead to serious accidents.  
 Ü Make sure no one can start the machine while you are working on it.  
 Ü Secure the machine against restarting and unintentional movements during assembly maintenance work.



**DANGER!**

Even a brief running of the machine during maintenance work can lead to accidents if the safety devices are not operating.  
 Ü Make sure that all safety devices are mounted and active.

**Lubricants**



**DANGER!**

Extended, intensive contact with synthetic oils can lead to skin irritations.  
 Ü Avoid extended contact with oil, and clean oil off skin thoroughly.



**DANGER!**

Hot oil may cause scalding.  
 Ü When changing oil, protect yourself against contacting hot oil.



**Attention**

Mixing different lubricants can impair the lubricant properties. This can destroy the gearhead.  
 Ü Only re-fill with the lubricant type that is in the gearhead.  
 Ü If you wish to use another lubricant, carry out a complete oil change (with flushing).



**Environment**

Lubricants (oils and greases) are hazardous substances, which can contaminate soil and water.  
 Ü Collect drained lubricant into suitable receptacles and dispose of it according to the valid national guidelines.

**3.4 Tightening Torques**

All screwed connections for which a tightening torque is specified, must on principle be tightened with a calibrated torque wrench, and checked.

**3.5 In case of fire**

The gearhead itself is not combustible. However, it usually contains a synthetic gear oil (polyglycol).

Ü Please observe the following instructions, if the gearhead is situated in a burning environment.

**3.5.1 Suitable extinguishing agents, Protective equipment**

Carbon dioxide, powder, foam, fog



**DANGER!**

High temperatures produce irritating steam.  
 Ü Use a protective breathing apparatus.

**3.5.2 Unsuitable extinguishing agents**

Do not spray with water!

### 3.5.3 Additional Information



#### Environment

Ü Prevent the penetration of the lubricant into drains, sewers, and water resources. You can receive further information on the lubricants directly from the manufacturer:

Standard lubricant TRIBOL® 800/220	Lubricants for the food industry (NSF-H1 registered)
Castrol Industrie GmbH, Mönchengladbach Tel.: +49 2161 909-30 www.castrol.com	Klüber Lubrication München KG, München Tel.: 49 89 7876-0 www.klüber.com

Table 3.1

## 4 Technical Specifications

### 4.1 Design

The gearheads are comprised of low-backlash angle gears.

All gearheads are factory-filled with oil; gear input and output sides are sealed with radial shaft sealings.

The clamping hubs enable a quick and easy mounting of the motor:

The motor is centred on the gearhead axle using the bearing-supported clamping hub and not the adapter plate. The motor can thus be mounted without radial distortion.

High flexibility is assured by being able to adapt the reducer to various motors through the functions of adapter plate and the spacer sleeve.

The gearhead has been designed to compensate for thermal linear expansion of the motor shaft.

For varying applications, the gearhead is available with:

- Output flange “VDT+”,
- Output shaft “VDS+/VDS<sub>e</sub>” and
- Hollow output shaft “VDH+/VDH<sub>e</sub>”.

#### 4.1.1 “VDT+” with output flange

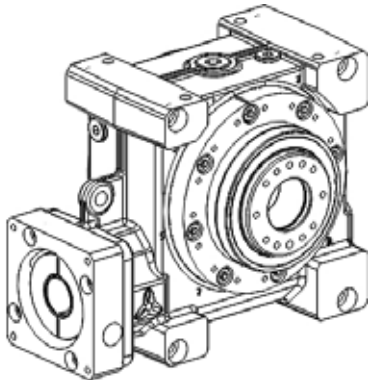

Fig 4.1

The output flange, in accordance with ISO 9409, has two centring mechanisms and a bore hole for an indexing pin so that the gearhead (or the application) can be zeroed mechanically.

The hollow shaft running through serves as a conduit for lines or hoses, but does not aid in securing the load. On the back side of the output flange, the position and/or the speed of the load can be measured through the hollow shaft.

#### 4.1.2 “VDS+” with output shaft

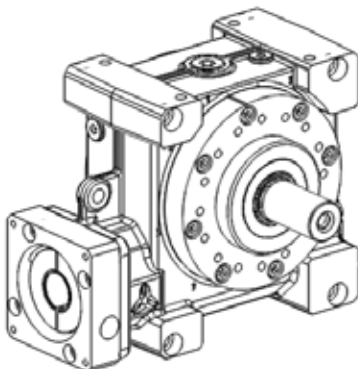

Fig 4.2

The output shaft is available in the following forms:

- Smooth face,
- With feather key groove (according to DIN 6885) or
- Involute (according to DIN 5480).

**4.1.3 “VDS+“ with output shaft on both sides**

The output shaft is available in the following forms:

- Smooth face or
- With groove for a feather key (according to DIN 6885).

**4.1.4 “VDSe“ with output shaft**

The output shaft is available in the following forms:

- Smooth face or
- With groove for a feather key (according to DIN 6885).

**4.1.5 “VDSe“ with output shaft on both sides**

The output shaft is available in the following forms:

- Smooth face or
- With groove for a feather key (according to DIN 6885).

**4.1.6 “VDH+/VDHe“ with hollow output shaft**

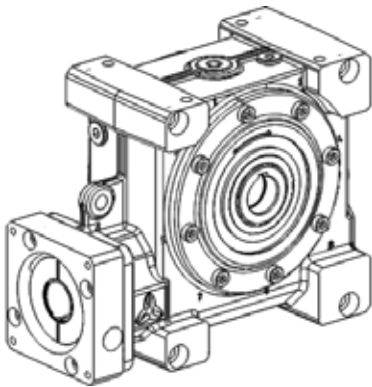

Fig 4.3

The output shaft is available in the following forms:

- Smooth face or
- With groove for a feather key (according to DIN 6885).

For the load shaft, we recommend the tolerance h6 (DIN ISO 286). The material must have a minimum yield stress of 385 N/mm<sup>2</sup>.

**4.2 Weight**

The weight of the gearhead ranges from 4 to 62 kg.

J The tables in section 5.2 help you in a more exact specification of the weights.

**4.3 Quantity of lubricant and types**

Ü Please observe the instructions in the “General Safety Instructions” in section 3.3.1 .

All gearheads are filled by the manufacturer with synthetic gear oil of viscosity class ISO VG 220 (Tribol 800/220).

The following table specifies all permitted oils of the viscosity class ISO VG 220. You can find additional information from the manufacturer at the specified Internet addresses.

Manufacturer	Lubricant	Internet address
Aral	Degol GS 220	www.aral-lubricants.de
BP	Energol SG-XP 220	www.bp.com
Esso	Glycolube 220	www.esso.de
Fuchs	Renolin PG 220	www.fuchs-oil.de
Klüber	Klübersynth GH 6-220	www.klueber.com
Optimol	Optiflex A 220	www.optimol.com
	Syntheso D 220 EP	-
Shell	Tivela Oil WB (PG 220)	www.shell.com
Tribol	800/220	www.castrol.com

Table 4.1

The filled lubricant and the required lubricant quantities are specified on the identification plate. These apply for the mounting position stated with the order.

Ü Correct the lubricant quantity, if required, according to the following tables.

The ambient temperature may not be under -15 °C and not over +40 °C. Operating temperature may not exceed +90 °C.



Divergent operating conditions may make different lubricant quantities and different lubricants necessary.

Ü In these cases, please consult our Customer Service Department (see 1.1).

You can find the lubricant quantities for your gearhead in the following sections. Please note the design version (e.g. VDT<sup>+</sup>), the size (e.g. 050) and the mounting position (e.g. AC) of the gearhead.

**4.3.1 Lubricant quantities VDT<sup>+</sup>, VDS<sup>+</sup> und VDSe**









Lubricant quantities [cm <sup>3</sup> ]										
Mounting position				Size						
				040	050		063		080	100
				VDSe	VDT <sup>+</sup> / VDS <sup>+</sup>	VDSe	VDT <sup>+</sup> / VDS <sup>+</sup>	VDSe	VDT <sup>+</sup> / VDS <sup>+</sup>	VDT <sup>+</sup> / VDS <sup>+</sup>
	AC		BC	270	600	500	900	800	2300	4500
	AD		BD	120	300	300	500	500	1200	2700
	AE		BE	270	500	500	900	800	2000	4200
	AE		BE	270	500	500	900	800	2000	4200
	AF		BF	270	600	500	900	800	2500	5700
	AG		BG	270	600	500	900	800	2500	5700

Table 4.2

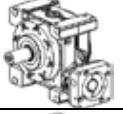
**4.3.2 Lubricant quantities VDH<sup>+</sup>, VDS<sup>+</sup> with output shaft on both sides and VDHe**

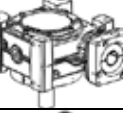

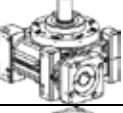
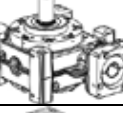
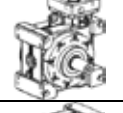
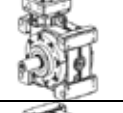

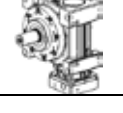

Lubricant quantities [cm <sup>3</sup> ]							
Mounting position			Size				
			040	050	063	080	100
		OC	270	500	800	2100	4400
		OD	120	300	500	1200	2700
		OE	270	500	800	2000	4200
		OF	270	500	800	2300	5500
		OG	270	500	800	2300	5500

Table 4.3

**4.4 Performance Statistics**

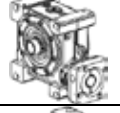
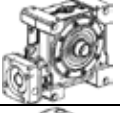
Please refer to our catalogue or our Internet page for the maximum permitted torques and speeds: [www.wittenstein-alpha.de/en](http://www.wittenstein-alpha.de/en).

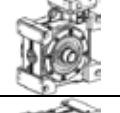
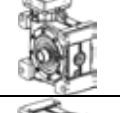
Ü Please consult our Customer Service Department (see 1.1) if your gearhead is older than a year. In this way you receive valid data.

**4.5 Noise emission**

Depending on the gearhead type and product size, the continuous sound pressure level is up to 70 dB(A).

Please contact our Customer Service Department if you need information regarding your particular product.

**4.6 Identification Plate**

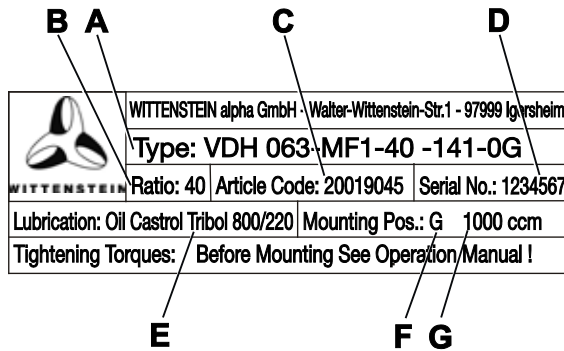

The following specifications can be found on the identification plate:

- A Ordering Key**
- B Ratio**
- C Article Code**
- D Serial number**
- E Lubricant**
- F Mounting position**
- G Lubricant quantity for the designated mounting position**

Fig. 4.4

## 4.7 Ordering Key

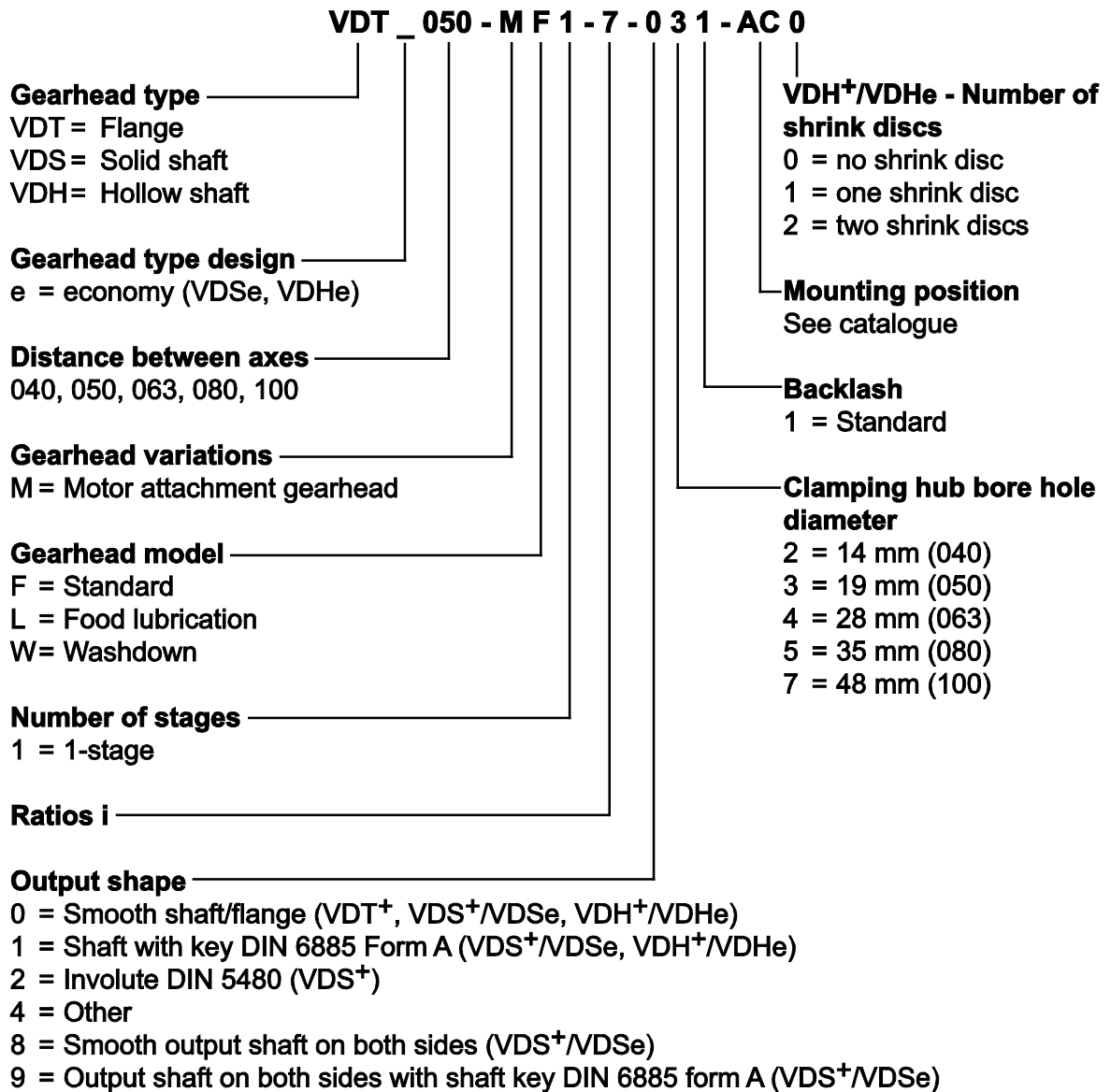

Fig 4.5

## 5 Delivery Status, Transport, Storage

### 5.1 Delivery Status

The gearheads are wrapped in foil (PE) and foamed (diphenylmethane) into the cardboard box.

Ü Please dispose of packing material according to the valid national regulations.  
All gearheads are treated with an anti-corrosion agent at the gear input and output.  
The gearheads are filled with lubricant by the manufacturer.

## 5.2 Transport

No special direction or position is prescribed to transport the gearhead.

The tables shown below are designed to help you specify the weights of your gearhead. The masses refer to the gearheads with standard adapter plates and the least oil level. With a different adapter plate and/or a different oil level, the actual mass can deviate by up to 10%.

Weight [kg]					
Size	040	050	063	080	100
Version					
VDT+	–	8.8	14.5	31	62
VDS+	–	8.5	15	32	61
VDSe	4.1	7.7	12.5	–	–
VDH+	4	7.4	12	26	50
VDHe	4	7.4	12	–	–

Table 5.1

### 5.2.1 Transport using hoisting equipment



#### **DANGER!**

Falling loads or breakage of fastening equipment can cause injury.

- Ü Do not stand under suspended loads.
- Ü Keep as safe a distance as possible from securing equipment.



#### **Attention**

Falling or hard placement can damage the gearhead.

- Ü Only use hoisting and securing equipment which is permitted for the size/weight of your gearhead.
- Ü Ensure that the load is slowly and carefully handled and placed.

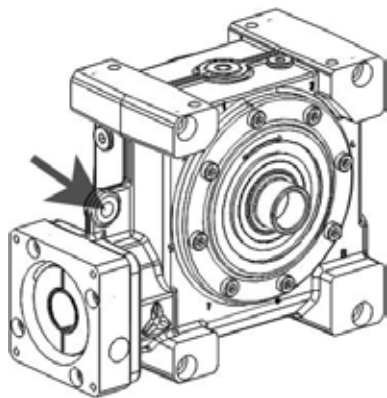

For gearheads as of model V-Drive+/V-Drive economy 050, there is an eyelet for securing equipment.

Fig. 5.1

## 5.3 Storage

The gear reducer can be stored dry and in a horizontal position in the original packing for a maximum of 2 years at a temperature between 0 °C and +40 °C. As storage logistic, we recommend the “first in - first out” principle.

## 6 Mounting, Putting into Operation

- Ü Please observe the instructions in the “General Safety Instructions” in section 3.3.1.

### 6.1 Preparation

All gearheads are treated with an anti-corrosion agent at the gear input and output.

- Ü Remove all traces of the anti-corrosion agent in all versions before mounting the gearhead.



#### Attention

Pressurised air can damage the gearhead seals, and thus lead to leakage.

- Ü Do not blow out the flanges with pressurised air when cleaning.

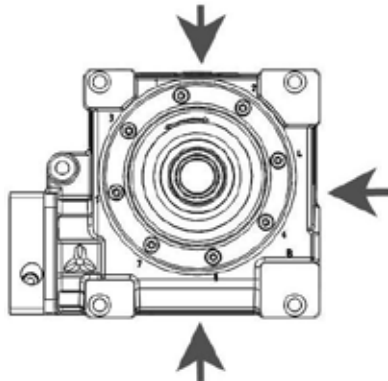

In the gear unit housing are four threaded bores on each of three surfaces (fig. 6.1).

- Ü Use all threaded bores of **one** surface to secure the gearhead to your machine.

Fig. 6.1

Threaded bores in the gear unit housing				
Gearhead size	Bolt size	Thread depth [mm]	Property class	Tightening torque [Nm]
040	M 6	11.0	8.8	9
050	M 8	13.5	8.8	24
063	M 10	17.0	8.8	48
080	M 12	19.5	8.8	83
100	M 12	19.5	8.8	83

Table 6.1

### 6.2 Mounting the Motor

#### 6.2.1 General Information

If the gearhead is not delivered with an attached motor, it is to be motor-mounted.

The motor to be mounted must:

- correspond to the B5 design,
- have a radial and axial runout tolerance of “N” according to DIN 42955 and
- if possible, have a smooth shaft.



#### Attention

Distortion can damage the motor and the gearhead.

- Ü Ensure that the motor is mounted in a vertical position.

#### 6.2.2 Tools for tightening the clamping hub

The clamping bolts M5 to M8 can be tightened through the mounting bores of the adapter plate using a square ¼ inch socket spanner.

The M10 clamping bolt requires a square ⅜ inch socket spanner, the M12 clamping bolts require a ½ inch socket spanner. In addition, calibrated torque wrenches are needed for the respective torque range.

6.2.3 **Assembly**

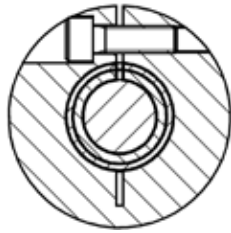

Smooth shaft with spacer sleeve

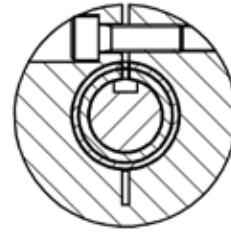

Grooved shaft with spacer sleeve

Fig. 6.2

- Ü If the motor shaft has a feather key, remove the feather key. A clamping hub connects the motor shaft and the gear drive shaft. A slotted spacer sleeve is additionally used for certain motor shaft diameters and applications (fig. 6.2).
- Ü Clean the plane fitting surfaces of the motor and gearhead.
- Ü Clean/de-grease the motor shaft, the clamping hub bore hole and, if required, the spacer sleeve.
- Ñ Take care that the slot of the spacer sleeve is positioned coincident to the slot of the clamping hub.
- Ü Turn the clamping hub so that the clamping screws are positioned coincident to the mounting holes in the adapter plate.



**Attention**

Excessively high axial forces can damage the motor and gearhead.

- Ü Ensure that the axial forces that occur are not higher than the values specified in Table 6.2.

Gearhead size	Clamping hub interior Ø [mm]	Clamping screw DIN EN ISO 4762-10.9	Width across flats [mm]	Tightening torque [Nm]	Max. axial force [N]
040	£ 14	M 5	4	8.5	42.5
050	£ 19	M 6	5	14	51
063	£ 28	M 8	6	30	49
080	£ 35	M 10	8	65	80
100	£ 48	M 12	10	115	118

Table 6.2



**Attention**

Motors with

- shaft shoulder,
- distinctive chamfer radius, or
- longer shafts than are permitted for the relevant gearhead

lead to distortions in mounting, which damage the motor and the gearhead.

- Ü Check the interfering edges by measuring, or by a measurement check based on our catalogue specifications and the information of the motor manufacturer.
- Ü Please consult our Customer Service Department to obtain a wider adapter plate or an intermediary flange.

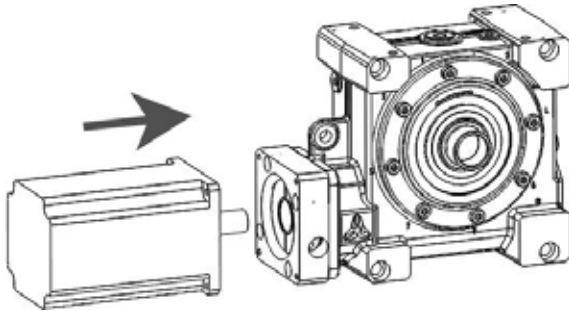

Fig 6.3

- Ü Position the motor so that the plane surfaces fit together. (fig. 6.3)
- Ñ Ensure that the motor allows itself to be moved into position “easily”.
- Ñ There is to be no gap between the motor and the gearhead.
- Ü Coat the screws with a screw-bonding agent (e.g. Loctite 221) and screw the motor and the adapter plate together.

- Ü Turn the screw in the clamping hub to the tightening torque (see table 6.2).
- Ü Press the supplied stopper plugs into the mounting bores of the adapter plate until they are flush with the surface.

### 6.3 Mountings on the gear output side

- Ü Thoroughly clean the output flange or shaft, centring, and fitting surface.

#### 6.3.1 Mountings on the output flange (version VDT+)

The output flange, in accordance with ISO 9409, has two centring mechanisms and a bore hole for an indexing pin so that the gearhead (or the application) can be zeroed mechanically.

The hollow shaft running through serves as a conduit for lines or hoses, but does not aid in securing the load.



#### Attention

Distortions during mounting operations can damage the gearhead.

- Ü Mount gearwheels and toothed belt pulleys onto the output flange without forcing.
- Ü Do not on any account attempt an assembly by force or hammering.
- Ü Only use suitable tools and equipment.

J You can find the prescribed tightening torques in the following table.

Thread in output flange					
	Gearhead size	Quantity x thread	Indexing bore hole Ø	Property class	Tightening torque [Nm]
	050	7 x M 6	6 H 7	10.9	14
	063	11 x M 6	6 H 7	10.9	14
	080	11 x M 8	8 H 7	10.9	34
	100	11 x M10	10 H 7	10.9	67

Table 6.3

#### 6.3.2 Mountings on the output shaft (version VDS+/VDSe, VDS+/VDSe with output shaft on both sides)

The output shaft is available in the following forms:

- Smooth face,
- With feather key groove (according to DIN 6885) or
- Involute (according to DIN 5480) (only VDS+).

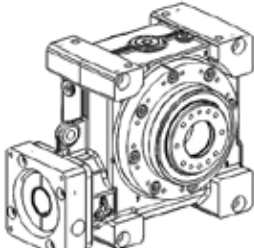

#### Attention

Distortions during mounting operations can damage the gearhead.

- Ü Mount gearwheels and toothed belt pulleys onto the output shaft without forcing.
- Ü Do not on any account attempt an assembly by force or hammering.
- Ü Only use suitable tools and equipment.
- Ü When shrink-fitting a gear onto the output shaft: Ensure that the maximum static axial forces (table 6.4) are not exceeded.

Output shaft		
	Gearhead size	$F_{\text{amax}}$ [N]
	040	6500
	050	10750
	063	18500
	080	31250
	100	49750

Table 6.4

**6.3.3 Assembly on the hollow shaft with shaft key (version VDH+/VDHe with groove)**

The shaft end of the machine must be equipped with a DIN 6885 Part 1, Form A shaft key and must have a DIN 332 Form DS centering (with thread).

- Ñ Check the hollow and load shafts for damaged edges or poor fit. Re-machine the parts if necessary and clean them.
- Ü Protect the cleaned contact surfaces against rust with a suitable lubricant (e.g. Klüger Altemp Q paste).

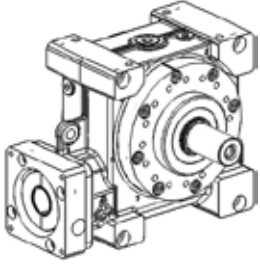

**Attention**

Incorrectly aligned shafts can lead to damage.

- Ü Ensure that the hollow shaft is aligned with the load shaft.

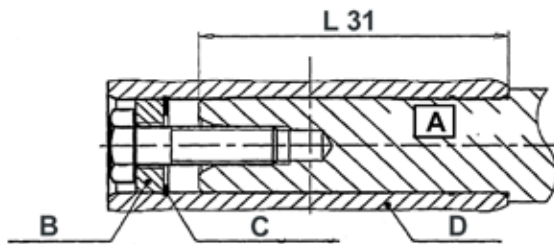

- J The axial securing of the hollow shaft gearhead to the load shaft (A) can be made with an end washer (B) and a retaining ring (C).
- J If the end washer is to be used for dismantling as a forcing washer, the load shaft (A) may not exceed a certain insertion length (L 31) in the hollow shaft (D). The maximum insertion lengths are specified in the following table.

Fig. 6.4

Gearhead size	Maximum insertion length L 31 [mm]
040	64
050	77
063	89
080	119
100	159

Table 6.5

**6.3.4 Mounting on the hollow output shaft with shrink disk (version VDH+/VDHe smooth)**

The hollow shaft is axially secured to the load shaft by means of a shrink disk connection. The shrinkable disk is delivered ready to be installed.

- Ü If a different shrink disk is used, observe the instructions of the manufacturer.
- J The material of the shrink disk is specified in the article code (AC) (see Table 6.7).



Depending on the material of the shrink disk, the load shaft has to meet the following conditions:

	Material of the shrink disk		
	Standard	Nickel-plated	Stainless steel
Minimum yield stress [N/mm <sup>2</sup> ]	≥ 385	≥ 260	≥ 260
Surface roughness Rz [µm]	≤ 16		
Tolerance	h6		

Table 6.6



**Attention**

Dirt can inhibit transmission of the torque.

Ü Do not disassemble the shrink disk prior to installation.

Ü De-grease the load shaft and the hollow output shaft's bore leaving no residual traces in the area of the shrink disk seat.

J Only the exterior surface of the hollow output shaft may be greased in the area of the shrink disk seat.



**Attention**

The forces of the shrink disk can deform the hollow output shaft.

Ü Always install the load shaft first before tightening the clamping screws of the shrink disk.

Ü Push the hollow output shaft onto the load shaft by hand.



**Attention**

Incorrectly aligned shafts can lead to damage.

Ü Ensure that the hollow output shaft is aligned with the load shaft.

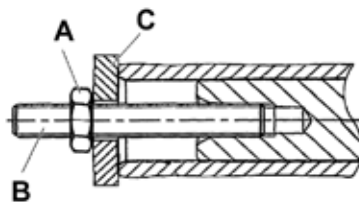

Fig. 6.5

Ü Mount the hollow output shaft onto the load shaft using a nut (A) and a threaded spindle (B). The supporting (C) has to be performed by the hollow output shaft.

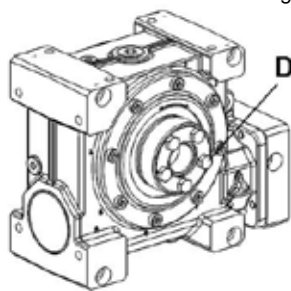

Fig. 6.6

The article code is located, depending on the design, on the front side or the circumference of the shrink disk.

Ü Refer to the article code to determine the material of the shrink disk.

Ü Tighten the clamping screws (D) of the shrink disk evenly distributed in multiple circular passes.

Ü Tighten the individual clamping screws only up to the maximum permitted tightening torque.

J For screw sizes and specified tightening torques, see Table 6.7.

Gearhead size V-drive	Material of the shrink disk: Standard		
	Article code (AC)	Tightening torque	Clamping screw thread
040	20001389	12 Nm	M6
050	20020687	13 Nm	M6
063	20020688	30 Nm	M8
080	20020689	34 Nm	M8
100	20020690	34 Nm	M10

<b>Material of the shrink disk: Nickel-plated</b>			
<b>Gearhead size V-drive</b>	<b>Article code (AC)</b>	<b>Tightening torque</b>	<b>Clamping screw thread</b>
<b>040</b>	20047957	7.5 Nm	M6
<b>050</b>	20047934	14 Nm	M6
<b>063</b>	20047530	34 Nm	M8
<b>080</b>	20047935	34 Nm	M8
<b>100</b>	20047927	34 Nm	M10
<b>Material of the shrink disk: Stainless steel</b>			
<b>Gearhead size V-drive</b>	<b>Article code (AC)</b>	<b>Tightening torque</b>	<b>Clamping screw thread</b>
<b>040</b>	20043198	7.5 Nm	M6
<b>050</b>	20047885	6.8 Nm	M6
<b>063</b>	20035055	16 Nm	M8
<b>080</b>	20047937	16 Nm	M8
<b>100</b>	20047860	16 Nm	M10

Table 6.7

- Ñ Check twice in a row that the clamping screws (D) have the maximum tightening torque.
- J For installing a shrink disk (supplied separately), see Chapter 9.2.2.

### 6.3.5 **Mounting the gearhead onto your machine**

- Ü Please observe the instructions in the „General Safety Instructions” in section 3.3.1.

#### **Check the lubricant quantity**

The gearheads are compliant for every mounting position; the lubricant quantity, however, is dependent on the mounting position.

The filled lubricant and the required lubricant quantities are specified on the identification plate. These apply for the mounting position stated with the order.

- Ü Correct the lubricant quantity, if required, according to the tables in section 4.3.

#### **Mounting the gearhead**

Mounting and connecting structures must be designed so that no vibrations from adjacent machinery parts and components are transmitted.

- Ü Coat the four screws with screw-bonding agent (e.g. Loctite 221), and screw the gear unit housing and your machine together.
- J You can find the prescribed screw sizes and tightening torques in table 6.1.

### 6.4 **Putting into operation**

- Ü Please observe the instructions in the „General Safety Instructions” in section 3.3.1.

## 6.5 Changing the torsional flank backlash (optional)

For special applications, there is the option of changing the torsional flank backlash.

- J The procedure for setting the torsional flank backlash can be found in the appendix: section 11.2.

## 7 Operation

### 7.1 Operating conditions

Ü Please observe the instructions in the „General Safety Instructions” in section 3.3.1.

The gearhead must be installed in a clean and dry environment. Coarse dust and liquids of all kinds impair its function.

The specifications for lubricants and operating temperatures can be found in section 4.3.

Ü Avoid icing, which can damage the seals.

Divergent operating conditions may make different lubricant quantities and different lubricants necessary.

Ü In these cases, please consult our Customer Service Department (see 1.1).



### **DANGER!**

Excessive loads or impacts can cause the output flange/output shaft to tear off.

Falling loads or breakage of machine parts can cause injury.

Ü Comply with the maximum permitted forces and torques.

Ü Do not stand under suspended loads.

Gearhead size	Maximum permitted forces	
	Max. axial force [N]	Maximum radial force [N]
040	3000	2400
050	5000	3800
063	8250	6000
080	13900	9000
100	19500	14000

Table 7.1

Gearhead size	Maximum permitted EMERGENCY-STOP torque [Nm]					
	Ratio i					
	4	7	10	16	28	40
040	118	126	125	129	134	122
050	230	242	242	250	262	236
063	460	484	491	494	518	447
080	938	993	963	1005	1064	941
100	1819	1932	1940	1955	2073	1856

Table 7.2

## 8 Maintenance

### 8.1 Shutdown, preparation

Ü Please observe the instructions in the „General Safety Instructions” in section 3.3.1.

Ü Shut down the machine in which the gearhead is installed.

Ü Disconnect the machine from the mains, before starting maintenance work.

**8.2 Inspection schedule**

Maintenance work/ See section...	Maintenance periods			
	At start-up	After 500 operating hours or 3 months	Every 3 months	Yearly
Visual inspection/8.3.1	X	X	X	
Checking the tightening torques/8.3.2	X	X		X
Oil change/8.3.3	Recommendation: initially after 7,000 operating hours and every 10,000 operating hours thereafter (after 5 years at the latest)			

Table 8.1

**8.3 Maintenance Work**

**8.3.1 Visual Inspection**

- Ü Check the entire gear reducer by carrying out a thorough visual inspection for exterior damage and oil leakage.
- Ü The sealings are subject to wear. Therefore also check the gear reducer for leakage during each visual inspection.

**8.3.2 Checking the tightening torques**

- Check the tightening torques of the fastening bolts on the gear unit housing.
- J You can find the prescribed tightening torques in the table 6.1 in section 6.
  - Ü Check the tightening torque of the clamping bolts on the motor mounting.
  - J You can find the prescribed tightening torques in the table 6.2 in section 6.

**8.3.3 Oil change**

- Ü Please observe the instructions in the „General Safety Instructions” in section 3.3.1.
  - J You can find a list of permitted lubricants in section 4.3.
- All gearheads are lubricated for their entire working life. However, we **recommend** an oil change after an initial 7,000 operating hours for synthetic oils, and then approx. every 10,000 operating hours thereafter. This is because oil becomes contaminated, causing increased wear and tear.

Gearhead size	All screws in accordance with DIN 908 with inner hexagon and flanged	
	large screw	small screws
040	G 3/8"	–
050	G 1/2"	G 1/4"
063	G 1/2"	G 1/4"
080	G 3/4"	G 1/4"
100	G 1"	G 1/4"

Table 8.2

**Lubricant exchange for gearhead model V-Drive+/V-Drive economy 040**

Ü Heat up the gearhead to operating temperature.

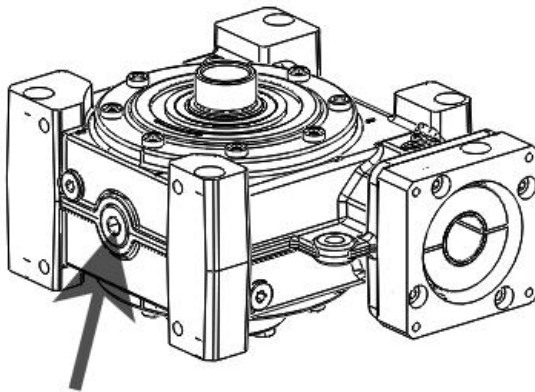

Fig. 8.1

Ü Drain the oil off through the plug (fig. 8.1).

Ü If draining is not possible in mounted position, dismantle the gearhead as described in section 9.

J There is now only residual oil and dirt in the gearhead. We recommend that these be flushed out:

- Screw in the plug and fill in oil.
- Let the machine run for a short time, and drain the oil off again.

Ü Fill with the prescribed quantity of oil.

J You can find the prescribed lubricant quantity in section 4.3.1 to 4.3.2.

Ü De-grease the plug and coat it with a sealant (e.g. Loctite 573).

Ü Screw in the plug (see also table 8.2).

Ü Should you have to dismantle the gearhead, remount it as described in section 6.

**Lubricant exchange for gearheads as of model V-Drive+/V-Drive economy 050**

Ü Heat up the gearhead to operating temperature.

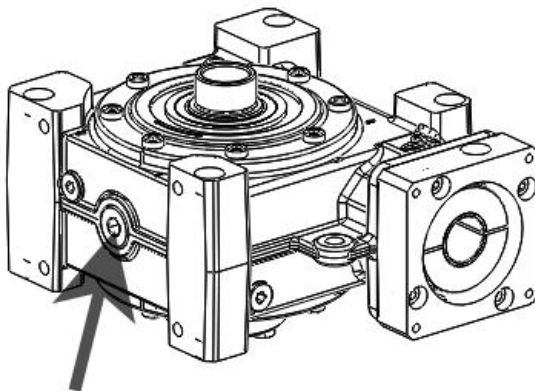

Fig. 8.2

Ü Drain the oil off through a plug located below. (fig. 8.2)

Ü If draining is not possible in mounted position, dismantle the gearhead as described in section 9.

Ü Open a plug situated at top, if possible, so that the gearhead is ventilated.

In the gear unit housing are one large and three small plugs (see also table 8.2).

J There is now only residual oil and dirt in the gearhead. We recommend that these be flushed out:

- Screw in the bottom plug, fill with oil, and screw in the top plug.
- Let the machine run for a short time, and drain the oil off again.

Ü De-grease the bottom plug and coat this with a bonding agent (e.g. Loctite 573).

Ü Fit the bottom plug in place (see also table 8.2).

Ü Fill with the prescribed quantity of oil.

J You can find the prescribed lubricant quantity in section 4.3.1 to 4.3.2.

Ü De-grease the top plug, and coat this with a bonding agent (e.g. Loctite 573).

Ü Fit the top plug in place (see also table 8.2).

Ü Should you have to dismantle the gearhead, remount it as described in section 6.

**8.4 Start-up after maintenance work**

- Ü Clean the outside of the gear reducer.
- Ü Assemble all safety devices.
- Ü Do a test run, before re-releasing the machine for operation.

**8.5 Malfunction list (troubleshooting)**

- Ü Seek an immediate solution if you notice oil loss, increased noise during operation or higher operating temperatures.

Malfunction	Possible cause	Solution
Higher operating temperature	Dimensioning insufficient	Check the technical data
	Motor heating the gearhead	Check the wiring of the motor, replace the motor or install insulation between motor and gearhead
	Ambient temperature too high	Ensure adequate cooling
	Oil quantity too high	Correct the oil level  <div style="background-color: #cccccc; padding: 5px; display: inline-block;"> <b>Attention</b>                          The gearhead can be damaged if the oil level is too low.                          Ü Do not allow too much oil to drain off.                     </div>
Increased noise during operation	Damaged bearings	Please consult our Customer Service Department.
	Damaged gear teeth	
Oil loss	Sealings not tight	Please consult our Customer Service Department.

Table 8.3

**9 Dismantling**

- Ü Please observe the instructions in the „General Safety Instructions” in section 3.3.1.

**9.1 Preparation**

- Ü Shut down the machine in which the gearhead is installed.
- Ü Make sure that it is possible to dismantle the gearhead without the risk of damage to the entire machine.
- Ü Before starting work, disconnect the machine from the mains.

**9.2 Disassembling the gearhead**

- Ü For gearheads with motor mounting, disconnect the electrical connections of the motor.
- Ü Secure the gearhead so it cannot fall.
- Ü Release the screws connecting the gearhead to the machine.
- Ü Remove the gearhead from its position with great care, so as to safeguard the gearhead and adjacent parts against damage.

**9.2.1 Dismantling of a slip-on gear mechanism with feather key**

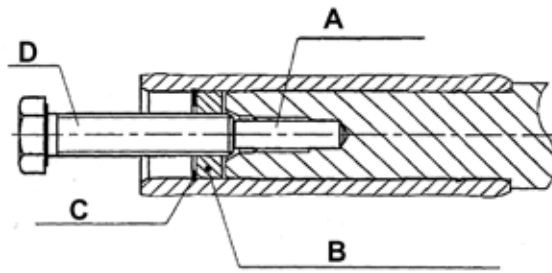

If the maximum insertion length has not been exceeded during assembly, the end washer may be used as a forcing washer.

- Ü Remove the screw in the end washer (B) and take it off.
- Ü Take off the retaining ring (C).
- Ü Place a cylinder pin (A) in the centring bore of the machine shaft to support it.
- Ü Insert the end washer (B) and replace the retaining ring (C).
- Ü Use an appropriate screw (D) to pull the hollow shaft from the machine shaft.

Fig. 9.1

J The table below lists the thread diameter of the required forcing screws.

Gearhead size	Forcing screw
040	M 8
050	M 12
063	M 12
080	M 16
100	M 20

Table 9.1

- Ü Remove the gearhead from its position with great care, so as to safeguard the gearhead and adjacent parts against damage.

**9.2.2 Dismantling of a slip-on gear mechanism with shrinkable disk**

- Ü Loosen the clamping screws one after another in multiple circular passes.
- Ü If the outer ring does not detach itself from the inner ring, remove a few of the clamping screws and screw into the adjacent extraction threads.
- Ü Remove the gearhead from its position with care, so as to safeguard the gearhead and adjacent parts against damage.
- J The removed shrink disk does not need to be disassembled and regreased prior to bracing again. Only if the shrinkable disk is dirty should it be disassembled and cleaned.



**Attention**

Cleaned shrink disks can have other coefficients of friction. This can lead to damage during mounting.

- Ü Lubricate the inner smooth surfaces of the shrink disk using a solid lubricant with a coefficient of friction of  $m = 0.04$ .

J The following lubricants are permissible for relubricating the shrink disk:

Lubricant	Commercial form	Manufacturer
<b>Molykote 321 R (lubricating varnish)</b>	spray	DOW Corning
<b>Molykote Spray (powder spray)</b>	spray	DOW Corning
<b>Molykote G Rapid</b>	spray or paste	DOW Corning
<b>Aemasol MO 19 P</b>	spray or paste	A. C. Matthes
<b>Unimoly P 5</b>	powder	Klüber Lubrication

Table 9.2

- Ü Push the shrink disk onto the hollow output shaft.
- J Only the exterior surface of the hollow output shaft may be greased in the area of the shrink disk seat.
- Ü Observe the further instructions given in Chapter 6.3.4 "Mounting on the hollow output shaft with shrink disk (version VDH+/VDHe smooth)".

9.3 Disassembling the motor

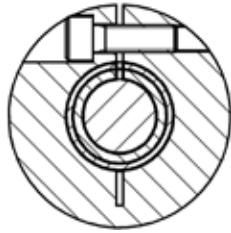

Smooth shaft with spacer sleeve

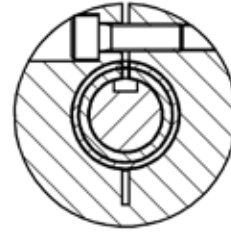

Grooved shaft with spacer sleeve

Fig.9.2

For gearheads with motor mounting, the motor shaft and the gearhead's drive shaft were connected with a clamping hub. A slotted spacer sleeve was additionally used for certain motor shaft diameters and applications (see fig. 9.2).



**Attention**

Distortion can damage the motor and the gearhead.

Ü Ensure that the motor is dismantled in a vertical position.

Ü Remove the plug stoppers from the mounting bores of the adapter plate.

Ü Loosen the screws in the clamping hub.

Ü Loosen the screws between motor and adapter plate.

Ñ The motor must allow itself to be removed "easily".

Ü Separate the motor and the gearhead.

The adapter plate and the spacer sleeve are part of the gear unit. Should you wish to return the gear unit, please include these parts.

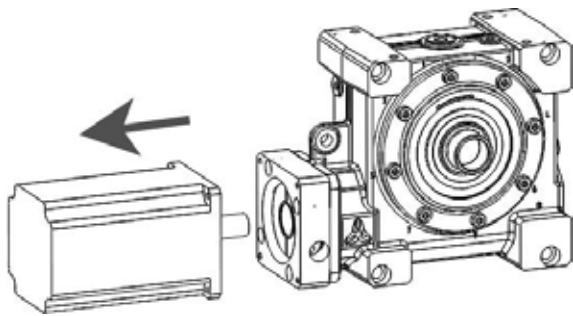

Fig. 9.3

10 Disposal

If our product is no longer of use and you wish to dispose of it, refer to the instructions here. If you have any questions regarding ecological disposal methods, please consult our Customer Service Department (see 1.1).

10.1 Lubricants

Ü Please observe the instructions in the „General Safety Instructions” in section 3.3.1.

Ü Allow all the lubricant to drain out and dispose of it according to regulations.

10.2 Sealing rings

Ü Remove the sealing rings from the gearhead, and clean them of oil and grease residues.

Ü Dispose of the sealing rings as composite material (metal/plastic)

10.3 Metal

Ü Divide up the remainder of the gearhead, if possible, into:

- iron
- aluminium (e.g. adapter plate), and
- non-ferrous heavy metal (e.g. motor windings).



## 11 Appendix

### 11.1 Tightening torques for common thread sizes in general mechanics

The specified tightening torques for headless screws and nuts are calculated values and are based on the following conditions:

- Calculation acc. VDI 2230 (Issue February 2003)
- Friction value for thread and contact surfaces  $\mu = 0.10$
- Exploration of the yield stress 90 %

Property class	Tightening torque [Nm] for threads												
	M 3	M 4	M 5	M 6	M 8	M 10	M 12	M 14	M 16	M 18	M 20	M 22	M 24
8.8	1.15	2.64	5.24	8.99	21.7	42.7	73.5	118	180	258	363	493	625
10.9	1.68	3.88	7.69	13.2	31.9	62.7	108	173	265	368	516	702	890
12.9	1.97	4.55	9	15.4	37.3	73.4	126	203	310	431	604	821	1042

Table 11.1

### 11.2 Setting the torsional flank backlash

#### Inspection

The gearhead is set by the manufacturer with a minimal torsional flank backlash. The process of wear, as well as extended operating times, can cause the backlash to increase.

#### Readjustment

Due to decreasing of the centre distance from worm gear shaft and worm wheel, the torsional flank backlash can be reduced.

- Ü If necessary, dismantle the gearhead from the entire machine as described in section 9.



#### Attention

If you remove the side cover of the gearhead, oil loss will result.

- Ü When performing adjustments, leave the cover in place.

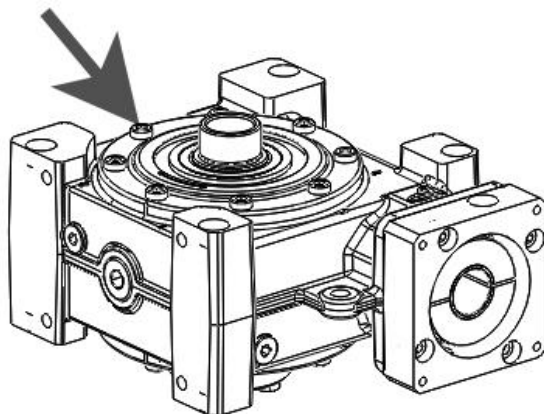

Fig. 11.1

- Ü Remove the inner hexagonal bolts on both side covers (see fig. 11.1).

On the covers are markings pointing to the numbers on the housing.

- Ü Turn the covers so that the marking points to the next highest number. Both covers must point to the same number.

- Ñ Check whether the tothing has enough backlash by turning the worm gear several times.

- Ü Reinsert the inner hexagonal bolts in the cover.

J The table below specifies the prescribed tightening torque.

Gearhead size	Tightening torque [Nm]
040	5
050	7
063	17
080	17
100	34

Table 11.2

- Ñ Check again whether the gear teeth still have adequate backlash.



alpha

WITTENSTEIN alpha GmbH  
Walter-Wittenstein-Straße 1  
97999 Igersheim

**WITTENSTEIN - being one with the future**

**[www.wittenstein.de](http://www.wittenstein.de)**